

FW9225 DC Series Fan

Fan Well

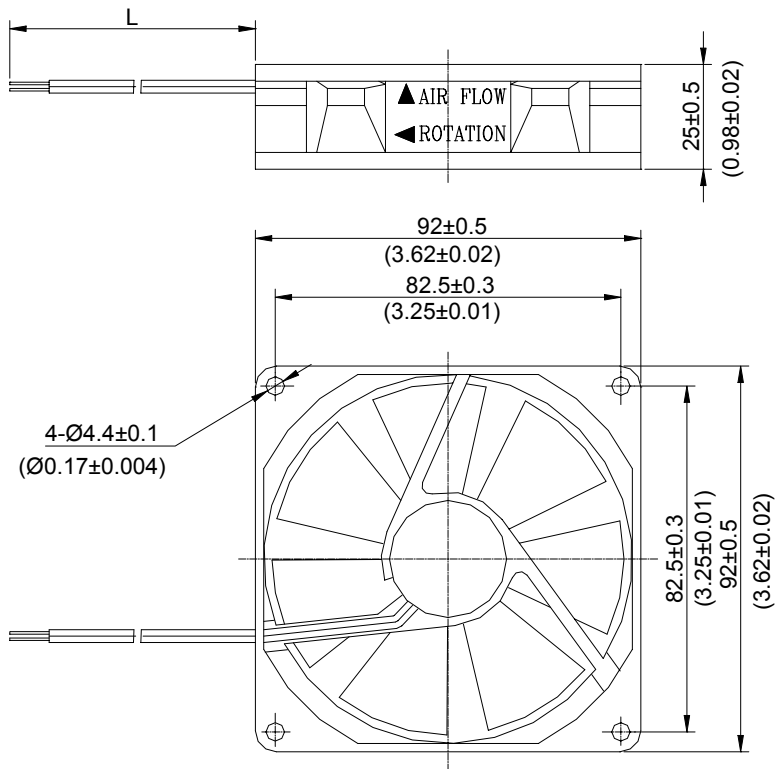

DC Fan
PERFORMANCE
 42-53 CFM



92mm sq. x 25mm (3.62 in sq. x 0.98 in)

FEATURES

- Motor:** Brushless DC with permanent magnet.
- Air Flow:** 41.9-53.00 CFM
- Weight:** 85g (2.99oz)
- Noise (dBA):** 23.51-32.61 dBA
- Housing & Impeller:** Glass filled thermoplastic in black color rated UL94V-0.
- Dielectric Strength:** 500VAC for one minute or 600VAC for 2 seconds between housing and lead wire(+).
- Insulation Resistance:** >500M Ohm between internal stator and lead wire (+) measured by 500VDC.
- Leads:** Two wires, Type UL 1007, +Red/-Black.
- Protection:** Locked rotor protected.
- Bearing System:** Sleeve or ball bearing.
- Standards:** UL, CUL, CE, TUV

Dimensions are in millimeters. () are in inches.
 Non-stock items may be subject to lead time.

FAN PERFORMANCE CURVES

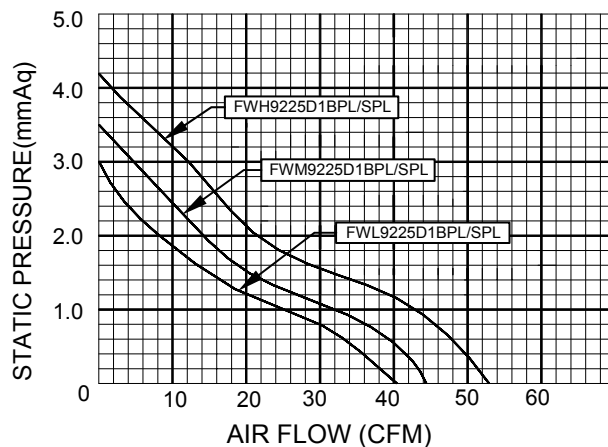

MODEL	PART NUMBER	BEARING SYSTEM	VOLTAGE (V/Hz)	STARTUP (V)	CURRENT (A)	SPEED (RPM)	AIR FLOW (CFM)	PRESSURE (mmAq)	NOISE (dBA)	LIFE EXP (Hours)	WEIGHT (g)
FW9225HD1	FWH9225D1BPL FWH9225D1SPL	Ball Sleeve	12	6	0.23	2800	53.0	4.15	32.32 32.61	50,000 30,000	85
FW9225MD1	FWM9225D1BPL FWM9225D1SPL	Ball Sleeve	12	6	0.19	2500	44.5	3.50	29.51 30.22	50,000 30,000	85
FW9225LD1	FWL9225D1BPL FWL9225D1SPL	Ball Sleeve	12	6	0.16	2000	41.9	2.97	23.51 23.54	50,000 30,000	85