

# THIN FILM CHIP RESISTORS



RNC

RNC 05, 10, 16, 20, 32, 50, 57, 63

MEGASTAR-OHMS thin film resistors have excellent performance in linearity, current noise, and high frequency applications. Low temperature coefficients and tight tolerances are characteristics that are not available from thick film technology. They are ideal for advanced high-density applications.

## Construction

The resistors are constructed out of a high-grade ceramic body. Internal metal electrodes are added at each end and connected by a resistive layer. The resistive layer is adjusted to give the approximate required resistance and laser cutting of this resistive layer that achieves tolerance trims the value. The resistive layer is covered with a protective coat and printed with the resistance value. Finally the two external terminations (matte tin) are added.

## Scope

This specification describe RNC05 to RNC63 high precision -high stability chip resistors with lead-free terminations made by thin film process.

## Features

1. Halogen Free Epoxy
2. RoHS compliant
  - Products with lead free terminations meet RoHS requirements.
  - Pb-glass contained in electrodes, resistor element and glass are exempted by RoHS
3. Reducing environmentally hazardous waste
4. High component and equipment reliability
5. Saving of PCB space
6. None forbidden-materials used in products/production

## Applications

1. Converters
2. Printer equipment
4. Server board
5. Telecom
6. Consumer

## Dimensions: Units: mm(inch)

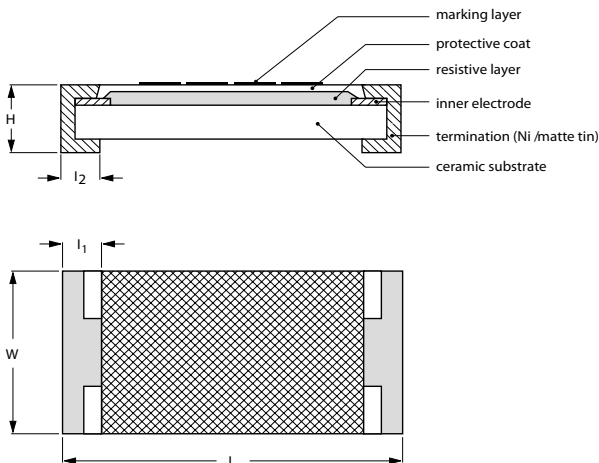

Units: Inch (mm)

Type	L	W	H	I1	I2
RNC05 (0201)	0.024 ± 0.002 (0.60 ± 0.05)	0.012 ± 0.002 (0.30 ± 0.05)	0.009 ± 0.001 (0.23 ± 0.030)	0.005 ± 0.002 (0.12 ± 0.05)	0.005 ± 0.002 (0.12 ± 0.05)
RNC10 (0402)	0.039 ± 0.002 (1.00 ± 0.05)	0.020 ± 0.002 (0.50 ± 0.05)	0.014 ± 0.002 (0.35 ± 0.05)	0.008 ± 0.004 (0.20 ± 0.10)	0.010 ± 0.002 (0.25 ± 0.10)
RNC16 (0603)	0.063 ± 0.008 (1.60 ± 0.20)	0.032 ± 0.008 (0.80 ± 0.20)	0.016 ± 0.004 (0.40 ± 0.10)	0.012 ± 0.008 (0.30 ± 0.20)	0.012 ± 0.008 (0.30 ± 0.20)
RNC20 (0805)	0.079 ± 0.008 (2.00 ± 0.20)	0.049 ± 0.008 (1.25 ± 0.20)	0.016 ± 0.004 (0.40 ± 0.10)	0.016 ± 0.008 (0.40 ± 0.20)	0.016 ± 0.008 (0.40 ± 0.20)
RNC32 (1206)	0.126 ± 0.008 (3.0 ± 0.20)	0.063 ± 0.008 (1.60 ± 0.20)	0.020 ± 0.004 (0.50 ± 0.10)	0.020 ± 0.012 (0.50 ± 0.30)	0.016 ± 0.008 (0.40 ± 0.20)
RNC50 (1210)	0.126 ± 0.008 (3.20 ± 0.20)	0.100 ± 0.008 (2.50 ± 0.20)	0.024 ± 0.008 (0.60 ± 0.20)	0.020 ± 0.012 (0.50 ± 0.30)	0.016 ± 0.008 (0.40 ± 0.20)
RNC57 (2010)	0.193 ± 0.006 (4.90 ± 0.15)	0.09 ± 0.006 (2.40 ± 0.15)	0.024 ± 0.004 (0.60 ± 0.10)	0.024 ± 0.012 (0.60 ± 0.30)	0.020 ± 0.010 (0.50 ± 0.25)
RNC63 (2512)	0.246 ± 0.006 (6.30 ± 0.15)	0.122 ± 0.006 (3.10 ± 0.15)	0.024 ± 0.004 (0.60 ± 0.10)	0.024 ± 0.012 (0.60 ± 0.30)	0.020 ± 0.010 (0.50 ± 0.25)

## PART NUMBERING SYSTEM

RNC		18		E		XXXX					J		T	
Type	Size	T.C.R.		Resistance Tolerance		Packaging								
RNC	Code Wattage (Size)	Code	ppm/°C	T	±0.01%	B	Bulk							
	05 1/20W (0201)	Y	±5ppm/°C	W	±0.05%	T	Tape & Reel (paper carrier)							
	10 1/16W (0402)	T	±10ppm/°C	B	±0.1%	TE	Tape & Reel (plastic carrier)							
	16 1/10W (0603)	B	±15ppm/°C	C	±0.25%									
	20 1/8W (0805)	E	±25ppm/°C	D	±0.5%									
	32 1/4W (1206)	C	±50ppm/°C	F	±1.0%									
	50 1/4W (1210)	K	±100ppm/°C											
	57 1/2W (2010)													
	63 3/4W (2512)													

Resistance Value: 4 DIGIT CODE					
Code	10R0	1001	1002	1003	1004
Values	10Ω	1KΩ	10KΩ	100KΩ	1MKΩ

First three digits are significant figures and third digit is number of zeros. Letter "R" indicates decimal values under 100 ohms.

# THIN FILM CHIP RESISTORS



RNC

RNC 05, 10, 16, 20, 32, 50, 57, 63

LEADFREE  
RoHS Compliant

## Ratings

Type	Power Rating @ 70°C (W)	Maximum Working Voltage*	Maximum Overload Voltage	Resistance Temperature Coefficient	Ohmic Rang and Tolerance				
					0.01%, 0.05%	0.1%	0.25%	0.5%	1%
RNC05 (0201)	1/20	15	30	±100 ppm/°C ±25 ppm/°C	-	-	-	- 33Ω-22Ω	10Ω-30Ω -
RNC10 (0402)	1/16	50	100	± 50 ppm/°C ±25 ppm/°C ±15 ppm/°C ±10 ppm/°C	- - - 50Ω-15KΩ	10Ω-121KΩ 10Ω-121KΩ 10Ω-100KΩ 10Ω-100KΩ	10Ω-121KΩ 10Ω-121KΩ 10Ω-100KΩ 10Ω-100KΩ	10Ω-121KΩ 10Ω-121KΩ - -	10Ω-121KΩ - - -
RNC16 (0603)	1/10	75	150	±100 ppm/°C ±50 ppm/°C ±25 ppm/°C ±15 ppm/°C ±10 ppm/°C	- - 1KΩ-47KΩ 1KΩ-47KΩ 50Ω-50KΩ	- 4.7Ω-332KΩ 4.7Ω-332KΩ 10Ω-100KΩ 10Ω-100KΩ	- 5.1Ω-681KΩ 10Ω-681KΩ 10Ω-100KΩ 10Ω-100KΩ	36Ω-330KΩ 4.7Ω-332KΩ 4.7Ω-332KΩ -	- 10Ω-332KΩ - -
RNC20 (0805)	1/8	150	300	±100 ppm/°C ±50 ppm/°C ±25 ppm/°C ±15 ppm/°C ±10 ppm/°C ±5 ppm/°C	- - 100Ω-100KΩ 100Ω-100KΩ 50Ω-100KΩ 100Ω-22KΩ	- 4.7Ω-1.5MΩ 4.7Ω-1.5MΩ 10Ω-100KΩ 10Ω-100KΩ -	110Ω-1MΩ 5.1Ω-1.5MΩ 10Ω-1.5MΩ 10Ω-100KΩ 10Ω-100KΩ -	110Ω-1MΩ 4.7Ω-1.5MΩ 4.7Ω-1.5MΩ - 100Ω-100KΩ -	- 5.1Ω-1.5MΩ 10Ω-100KΩ - - -
RNC32 (1206)	1/4	200	400	±100 ppm/°C ±50 ppm/°C ±25 ppm/°C ±15 ppm/°C ±10 ppm/°C ±5 ppm/°C	- - 100Ω-100KΩ 100Ω-100KΩ 50Ω-200KΩ 100Ω-30KΩ	10Ω-1MΩ 4.7Ω-1.5MΩ 10Ω-1.5MΩ 10Ω-100KΩ 10Ω-200KΩ -	10Ω-1MΩ 5.1Ω-1.5MΩ 10Ω-1.5MΩ 10Ω-100KΩ 10Ω-130KΩ -	10Ω-1MΩ 4.7Ω-1.5MΩ 4.7Ω-1.5MΩ - 100Ω-130KΩ -	- 5.1Ω-1.5MΩ 10Ω-130KΩ - - -
RNC50 (1210)	1/4	200	400	±50 ppm/°C ±25 ppm/°C ±15 ppm/°C ±10 ppm/°C	- 100Ω-100KΩ 100Ω-100KΩ 100Ω-100KΩ	10Ω-1MΩ 10Ω-2MΩ 10Ω-100KΩ 10Ω-330KΩ	5.1Ω-1MΩ 10Ω-1MΩ 10Ω-100KΩ 10Ω-240KΩ	5.1Ω-1MΩ 10Ω-1MΩ - 100Ω-240KΩ	5.1Ω-1MΩ 10Ω-510Ω - -
RNC57 (2010)	1/2	200	400	±50 ppm/°C ±25 ppm/°C ±15 ppm/°C ±10 ppm/°C	- 100Ω-100KΩ 100Ω-100KΩ 100Ω-100KΩ	4.7Ω-1MΩ 4.7Ω-1MΩ 10Ω-100KΩ 10Ω-100KΩ	10Ω-1MΩ 10Ω-1MΩ 10Ω-100KΩ 10Ω-100KΩ	4.7Ω-1MΩ 4.7Ω-1MΩ - -	10Ω-1MΩ - - -
RNC63 (2512)	3/4	200	400	±50 ppm/°C ±25 ppm/°C +15 ppm/°C ±10 ppm/°C	- 100Ω-100KΩ 100Ω-100KΩ 100Ω-100KΩ	4.7Ω-1MΩ 4.7Ω-1MΩ 10Ω-100KΩ 10Ω-100KΩ	4.7Ω-1MΩ 4.7Ω-1MΩ 10Ω-100KΩ 10Ω-100KΩ	4.7Ω-1MΩ 4.7Ω-1MΩ - -	10Ω-1MΩ - - -

\* Lesser of  $\sqrt{PR}$  or maximum working voltage

## Environmental Characteristics

Performance	Test Method	Rating
Temperature Coefficient (by type)	MIL-STD-202F, Method 304, -55°C to +125°C	±25-100 ppm/°C
Thermal Shock	MIL-STD-202F, Method 107, 5 cycles, -65°C to +155°C	±(0.5% + 0.05Ω)
Low Temperature Operation	MIL-R-55342D, Para.4.7.4, One hour at -65°C followed by 45 minutes RCWV	±(0.5% + 0.05Ω)
Short Time Overload	MIL-R-55342D, Para.4.7.5, 2.5 times RCWV for 5 seconds	±(0.5% + 0.05Ω)
High Temperature Exposure	MIL-R-55342D, Para.4.7.6, 125°C for 100 hours	±(0.5% + 0.05Ω)
Resistance to Soldering Heat	MIL-R-55342D, Para.4.7.7, Soldered to test board at 260°C for 10 seconds	±(0.5% + 0.05Ω)
Moisture Resistance	MIL-STD-202F, Method 106, 10 cycles, Total 240 hours	±(0.5% + 0.05Ω)
Life	MIL-STD-202F, Method 108A, 100 hours at 70°C RWV intermittent.	±(0.5% + 0.05Ω)
Solderability	MIL-STD-202F, Method 208, 230°C for 5 seconds	95% min. coverage
Bending Strength	Unit mounted in center of 90mm board length, deflected 5mm in either direction for 10 seconds	±(0.5% + 0.05Ω)

## Power Derating Curve

