

Low Capacitance TVS Arrays

The series are an ultra low capacitance TVS array designed to protect high speed data interfaces. This series has been specifically designed to protect sensitive components which are connected to data and transmission lines from overvoltage caused by ESD (electrostatic discharge), CDE (Cable Discharge Events), and Lightning. The unique design incorporates surge rated, low capacitance steering diodes and a TVS diode in a single package. During transient conditions, the steering diodes direct the transient current to ground. The internal TVS diode clamps the transient voltage to a safe level. The ultra low capacitance array configuration allows the user to protect up to the high-speed data lines.

These devices are in a signal package, RoHS/WEEE compliant, SOD-323 package. It measures 2.5 x 1.25 x 1.0mm.

The series devices may be used to meet the immunity requirements of IEC 61000-4-2, level 4.



HBM : ±8kV
Air Mode : ±15kV

SPECIFICATION FEATURES

- IEC61000-4-2 ESD 15kV Air, 8kV contact compliance
- SOD-323 surface mount package
- Protects one I/O line
- Peak power dissipation of 350W under 8/20µs waveform
- Working voltage : 3V, 5V, 12V, 15V and 24V
- Low leakage current
- Low operating and clamping voltages
- Solid-state silicon avalanche technology
- Lead Free/ RoHS Compliant

APPLICATIONS

- USB 2.0 / 3.0 Interface
- MMC Port
- Digital Visual Interface (DVI)
- Serial ATA Protection

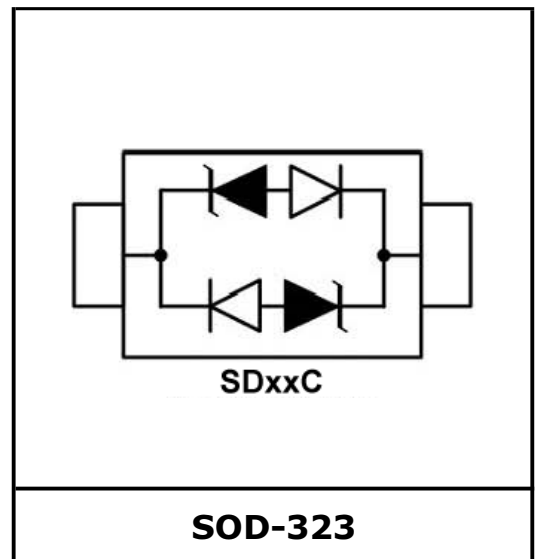

MAXIMUM RATINGS

Rating	Symbol	Value	Unit
Peak Pulse Power (8/20μs waveform)	P_{PP}	350	W
ESD Voltage (HBM Contact)	V_{ESD}	±8	kV
ESD Voltage (AIR Contact)		±15	
Lead Soldering Temperature	T_L	260	°C
Storage & Operating Temperature Range	T_{STG}, T_J	-55~+150	°C

ELECTRICAL CHARACTERISTICS (T_J=25°C)

Device	Marking	V_{RWM}	V_B	I_T	I_R	V_C	V_C		C_T
		(V)	(V)		(μA)	@1A	Max.	@A	(pF)
		Max.	Min.		Max.	Max.			typ.
SD03C	AC	3	4	1	20	5.15	13.9	15	0.8
SD05C	BC	5	6	1	5	9.8	18.3	17	0.8
SD12C	DC	12	13.3	1	1	19.0	28.6	11	0.8
SD15C	EC	15	16.7	1	1	24	31.8	10	0.8
SD24C	HC	24	26.7	1	1	43	56	6	0.8

TYPICAL CHARACTERISTICS CURVES

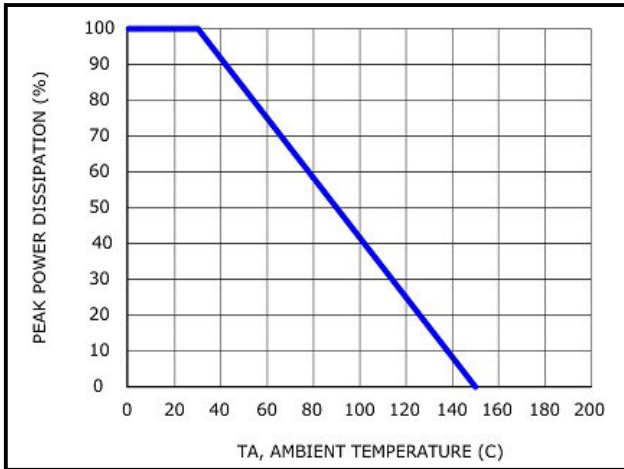

Figure 1. Power Derating Curve

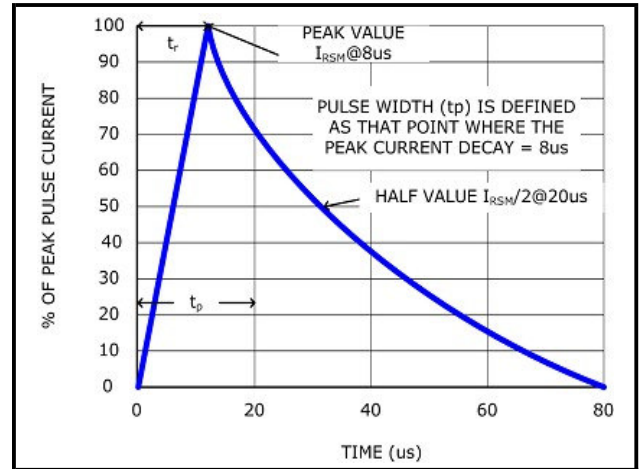

Figure 2. 8/20µs Pulse Waveform

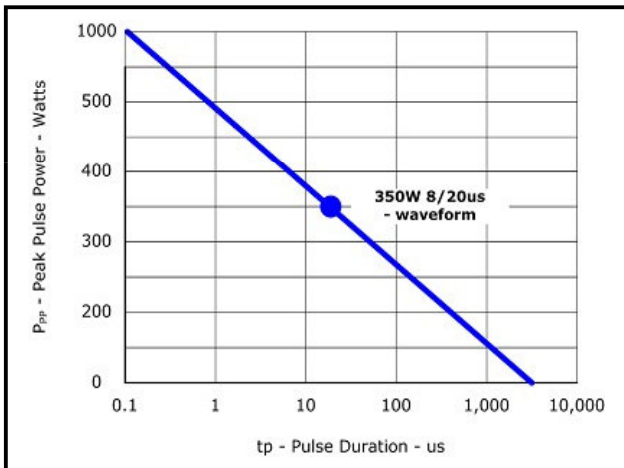

Figure 3. Non-Repetitive Peak Pulse vs. Pulse Time

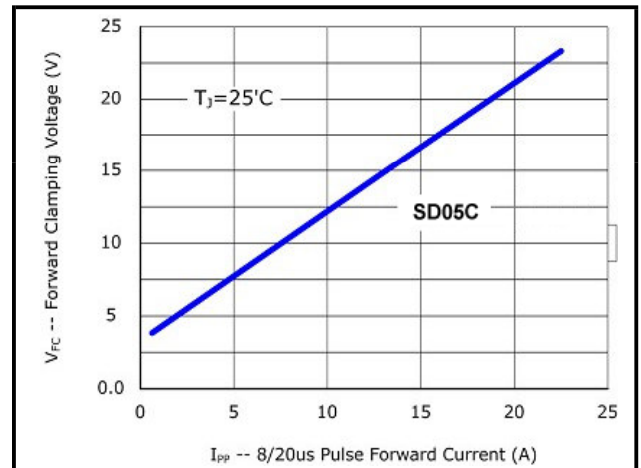

Figure 4. Clamping Voltage vs. Peak Pulse Current

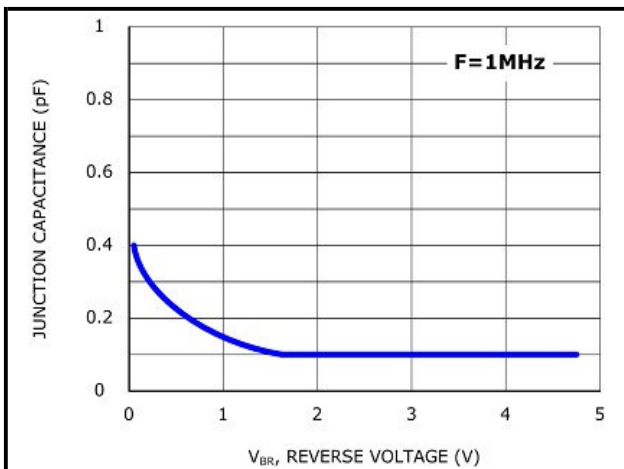

Figure 5. Capacitance vs. Reverse Voltage

PACKAGE AND SUGGESTED PAD LAYOUT DIMENSION

SOD-323

