



**PRO-CAP CERAMIC CAPACITORS** are designed and produced to offer the user a high capacitance, small size unit. The wide selection of temperature characteristics and voltage ratings, all built with a rugged environmental coating, allows the user a wider choice for a particular application. Termination: 100% tin coated copper wire.

**SPECIFICATIONS**

- ◆ **Temperature Characteristics:** See table and curves.
- ◆ **Operating Temperature:** -55°C to +85°C.
- ◆ **Test Voltage:** 2.5 times working voltage for 1 second.
- ◆ **Insulation Resistance:**  
7,500 Megohms or an RC product of 75-ohms F, whichever is less.  
RC product of .04-ohms F for 12VDCW Y5T.  
RC product of .1-ohm F for 16VDCW Y5T.  
10,000 Megohms for NPO.
- ◆ **Q (Ratio of Reactance to Equivalent Series Resistance):**  
Capacitance ≤ 30 pf Q ≥ 400 + 20 x CPf  
Capacitance > 30 pf Q ≥ 1000
- ◆ **Dissipation Factor:**  
For Z5F, Z5R, Z5U, Y5P (@ 1KC and 25°C) 2.5%  
For Z5V 5% For S2L, S3N 0.6%  
For Y5T 8% For NPO, N750, N1500 0.2%
- ◆ **Encapsulation:** Phenolic coated, wax impregnated.
- ◆ **Marking:** Value, Working Voltage, Tolerance, Temperature Coefficient as Space Permits

**Temperature Characteristics**

Type	Temp Range (°C)	Max Change in Capacitance
NPO	-55 - +85	0 ± 60 ppm /°C
N750	-55 - +85	-750 ± 130 ppm /°C
N1500	-55 - +85	-1500 ± 250 ppm /°C
S2L	-55 - +85	N330 ± 500 ppm /°C
S3N	-55 - +85	N3300 ± 2500 ppm /°C
Y5F	-30 - +85	+7.50%
Z5F	+10 - +85	+7.50%
Y5P	-30 - +85	+10%
Z5R	+10 - +85	+15%
Z5T	+10 - +85	+22% -33%
Y5U	-30 - +85	+22% -56%
Z5U	+10 - +85	+22% -56%
Z5V	+10 - +85	+22% -82%

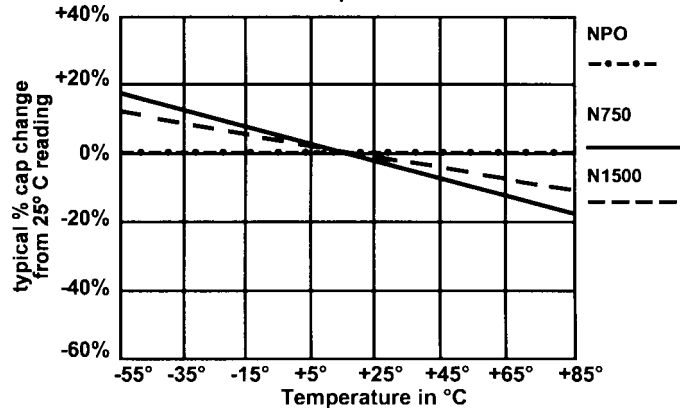
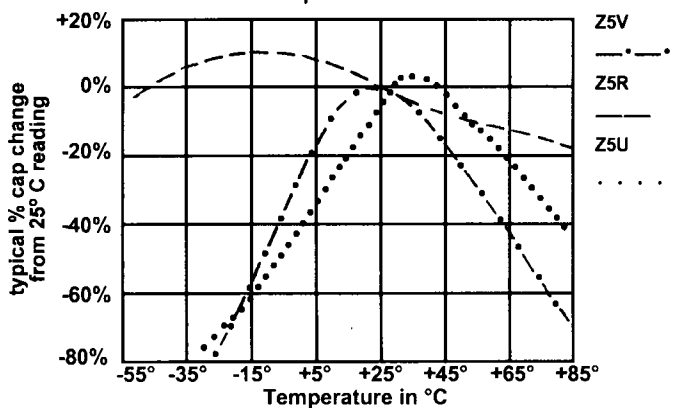
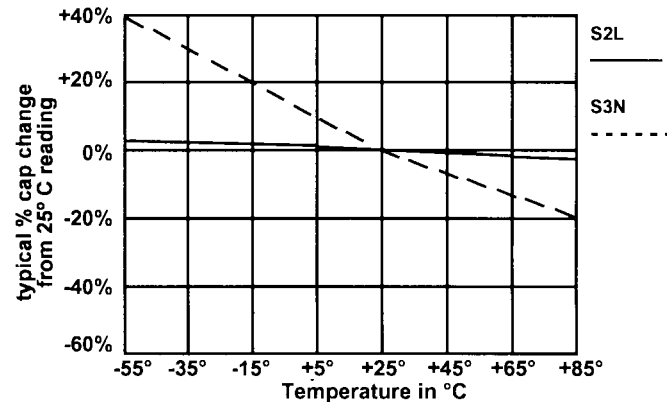
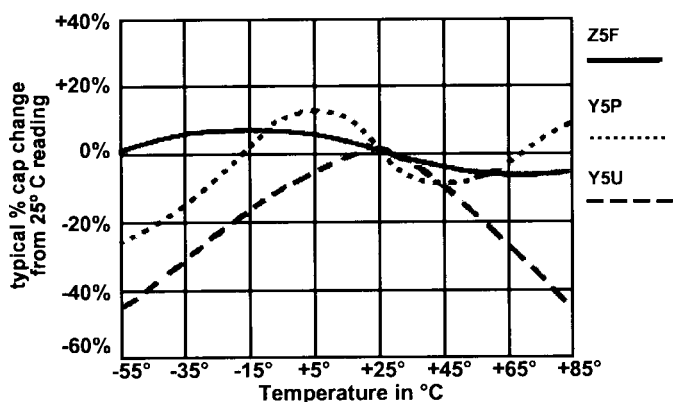

# Soldering Profile

## Disc Ceramic Capacitor (Lead free)

- Soldering Heat Resistance as below Temperature profile.
- Solder Iron 400°C 4~5sec
- Solderability 235°C, 3±1sec, 95% coverage min.

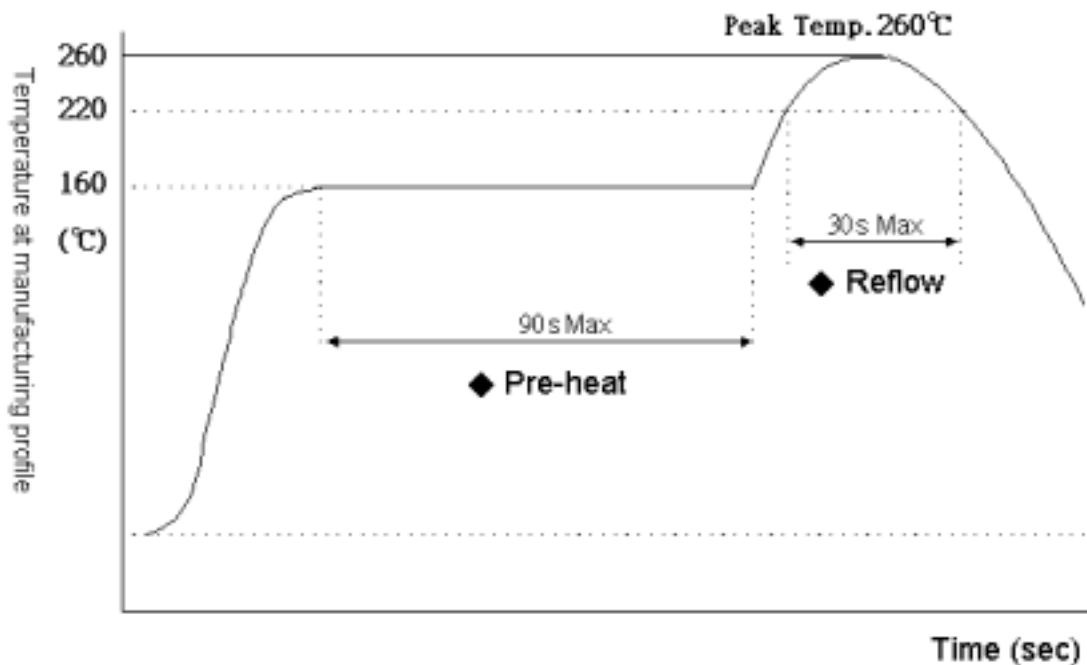

- ◆ Pre-heating shall be done less than +150°C within 90 seconds
- ◆ The temperature at capacitor top shall not exceed +260°C
- ◆ The duration of over +220°C temperature at component top shall not exceed 30 seconds
- ◆ The standard temperature profile differs by each reflow method

If components are subject to the conditions beyond the allowable range of reflow please contact us.



**HOW TO ORDER**

CODE 1

CODE 2

CODE 3

CODE 4

...

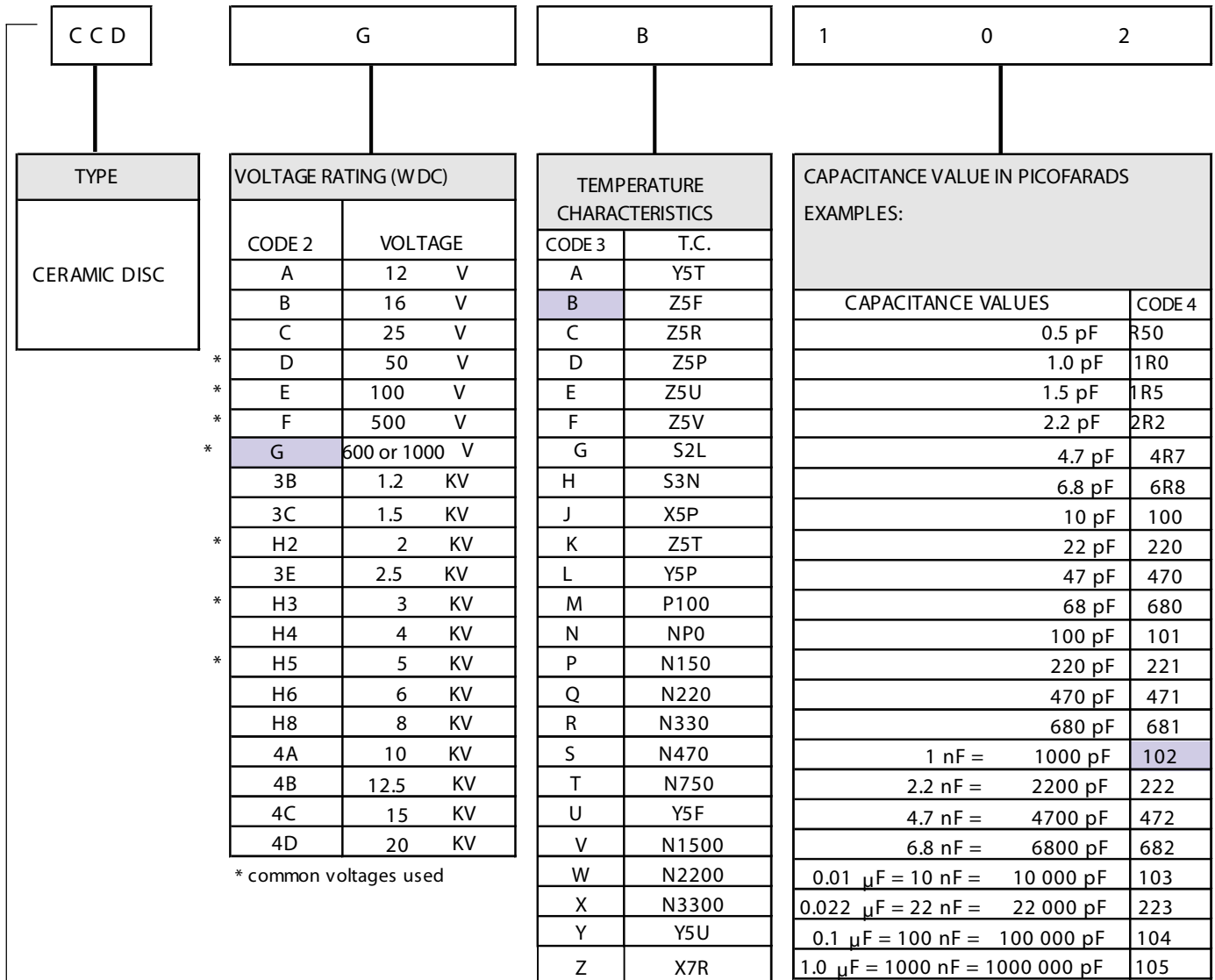

\* common voltages used

Capacitance Codes, expressed in picofarad (p)  
 First 2 digits are significant  
 Third digit represents the number of zeros  
 "R" indicates decimal for values under 10 pF.

DESCRIPTION FOR THE ABOVE PART #

CCD GB 102 K 5 F 12

Ceramic Disc Capacitor:

1000 Volts / Z5F / 1000 pF / K = ±10% Tolerance / Lead Spacing 5.0 mm /  
 Lead Style Figure F on page 40 (Custom Spec.) / Lead Length 12 mm



LEAD LENGTH ONLY USED FOR FIGURE F  
(NON-STANDARD LEAD STYLE CAPACITORS)

... CODE 5

CODE 6

CODE 7

CODE 8

**K**

TOLERANCE	
CODE 5	Tolerance
C	± .25 pF
D	± .50 pF
F	± 1%
G	± 2%
J	± 5%
K	± 10%
M	± 20%
Z	± 80%, -20%
GMV	Guaranteed Min. Value

**5**

LEAD SPACING		
CODE 6	Measure (mm)	Inches
2	2.5	0.1
5	5.0	0.2
6	6.35	0.25
7	7.5	0.3
9	9.5	0.375
12	12.7	0.5

See Page 42, Table I for Standard Specs.

**F**

PACKAGING	LEAD STYLE	
	Figure	CODE 7
BULK	A	A
	B	B
	C	C
	D	D
	E	E
	F	F
	G	G
	H	H
	I	I
	TAPED	
K		KR
L		LA
L		LR

\* See Figures on Page 40 & 41

\* NOTE: Figure F is Non-Standard  
CODE 8 must be specified in mm

**12**

LEAD LENGTH		
Using CODE 7	CODE 8 (in mm)	
<b>NON-STANDARD ITEMS</b>		
<b>F</b>	Lead length must be specified in millimeters (mm) since <b>Figure F</b> is the only NON-STANDARD Figure shown on <b>Page 40</b>	
<b>STANDARD ITEMS</b>		
A	Lead length specifications for CODE 8 are NOT required for these standard dimensions  see <b>Page 40</b>	
B		
C		
D		
E		
G		
H		
I		
KA		see dimensions <b>Page 41</b>
KR		
LA		
LR		

EXAMPLES (Fig. F)	
CODE 8	Measure of Lead Length
12	12 mm
28	28 mm
39.5	39.5 mm
57	57 mm

**CODE 9** (only for epoxy coating)

All capacitors are made with brown color (Durez Coating). Upon customer's request add letter "X" at the end of the part number for blue color epoxy coating.

**EXAMPLE FROM PAGE 48**

"TYPE" FOR STANDARD ITEMS

TYPE: GB 471 K

CODE (1) (2) (3) (4) (5) (6) (7) (8)

PART # **CCD** **G** **B** **471** **K**

AS PER CUSTOMER'S REQUIREMENT

**LEAD STYLE: CODE 7**

Unit: mm

Fig. A	Fig. B	Fig. C	Fig. D	Fig. F
				
Standard	Pre-Cut	Inner Kinked (Short)	Outer Kinked (Short)	Custom Spec.

Fig. G	Fig. H	Fig. I	Fig. K	Fig. L												
			<table border="1"> <thead> <tr> <th>Code</th> <th>Packaging</th> </tr> </thead> <tbody> <tr> <td>KA</td> <td>AMMO</td> </tr> <tr> <td>KR</td> <td>TAPE &amp; REEL</td> </tr> </tbody> </table>	Code	Packaging	KA	AMMO	KR	TAPE & REEL	<table border="1"> <thead> <tr> <th>Code</th> <th>Packaging</th> </tr> </thead> <tbody> <tr> <td>LA</td> <td>AMMO</td> </tr> <tr> <td>LR</td> <td>TAPE &amp; REEL</td> </tr> </tbody> </table>	Code	Packaging	LA	AMMO	LR	TAPE & REEL
Code	Packaging															
KA	AMMO															
KR	TAPE & REEL															
Code	Packaging															
LA	AMMO															
LR	TAPE & REEL															
Double Kinked	Inner Kinked (Long)	Outer Kinked (Long)	See Page 41 for details	For other specifications not shown, please contact us for information See Tape & Reel and Ammo Pack Page 41												
			Kinked (TAPED)	Straight (TAPED)												

**NOTE:** \* For other lead variations consult distributor  
 \* Disc ceramic capacitors may be supplied on tape and reel in accordance with EIA specification RS468.

**STANDARD STYLES:** Figure A, B, C, D, G, H, I, K (KA, KR), L (LA, LR)

**NON-STANDARD STYLES:** Figure F (Code 8 required)

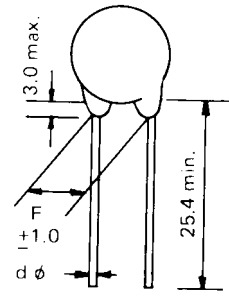
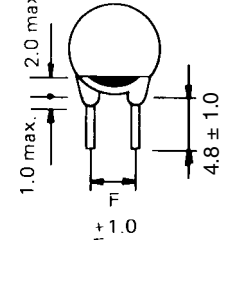
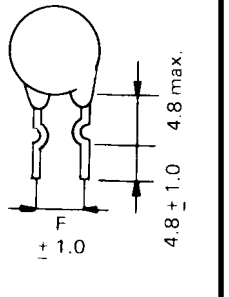
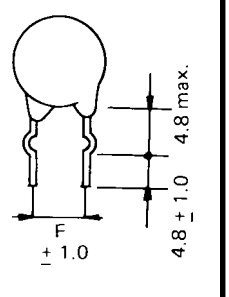
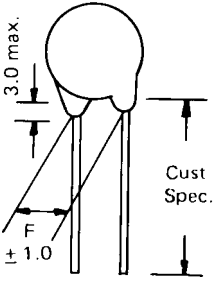
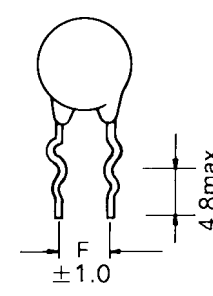
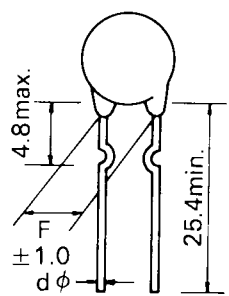
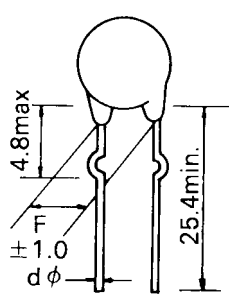

LEAD STYLES: RADIAL TAPED TYPE

RADIAL TAPED TYPE

Fig. K

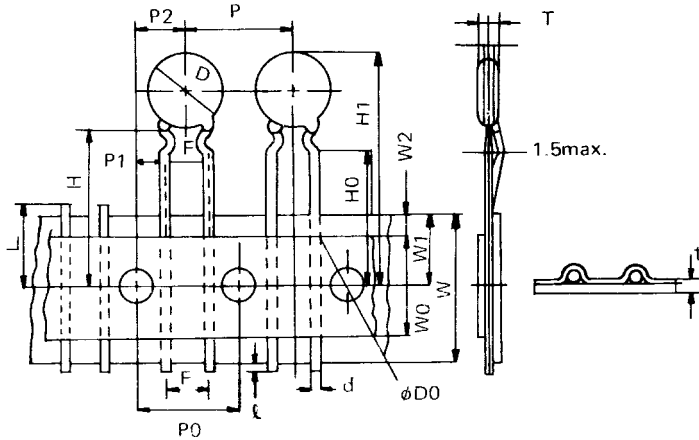

S56 Fig. L

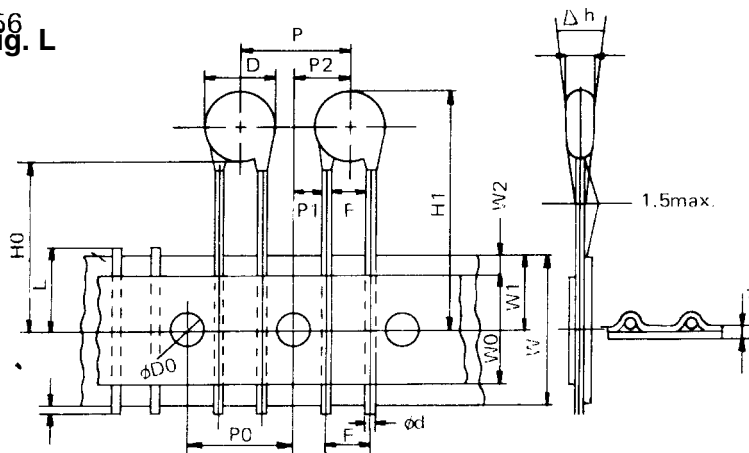

Symbol	Dimensions (mm)
D	11.0 max.
T	3.5 max.
d	0.6 ±0.05
P	12.7 ±1.0
P0	12.7 ±0.3
P1	3.85 ±0.7
P2	6.35 ±1.3
F	5.0 ±0.8
Δ h	0 ±2.0
W	18.0 +1.0 -0.5
W0	11.5 min.
W1	9.0 +0.75 -0.5
W2	6.0 max.
H	20.0 +1.5 -1.0
H0	16.0 ±0.5
H1	32.25 max.
ℓ	1.0 max.
D <sub>0</sub>	4.0 ±0.2
t	0.7 ±0.2
L	11.0 max.

Accumulative tolerance is ±2mm over adjacent continuous 20 pitches.

Start and end tape should be a lead tape with length of at least 5 pitches.

PACKAGING

<p><b>REEL PACK</b></p> <p>2000 – 3000 pcs. per reel depending upon dia. of capacitor</p>	<p><b>AMMO PACK</b></p> <p>● Flat package 2000 – 3000 pcs. per box.</p>
---	---



**TABLE I - STANDARD SPECIFICATIONS**

Unit: mm

WORKING VOLTAGE	DISC		LEAD		
	DIAMETER	THICKNESS	CODE 6: SPACING	LENGTH (for Figures A, H, I)	DIAMETER (dØ)
12V - 50V 100V	1 - 5	3.0	2.5	25.4	0.48
	5.1 - 15	3.0	5.0	25.4	0.48
	15.1	3.0	9.5	25.4	0.65
500V	1 - 7	4.0	5.0	25.4	0.65
	7.1 - 10	4.0	6.35	25.4	0.65
	10.1 - 25	4.0	9.5	25.4	0.65
1KV	1 - 10	4.0	6.35	25.4	0.65
	10.1 - 25	4.0	9.5	25.4	0.65

\* Other spacing and lead diameter available upon request

**EXAMPLES:**

**Ceramic Disc Capacitor** 1000pF / 1000 Volts / 10% / Z5U / Lead Spacing 5.0 mm / Tape & Reel Kinked Style /

CODES	(1)	(2)	(3)	(4)	(5)	(6)	(7)
PART #	<b>CCD</b>	<b>G</b>	<b>E</b>	<b>102</b>	<b>K</b>	<b>5</b>	<b>KR</b>

**Ceramic Disc Capacitor** 68pF / 100 Volts / 5% / NPO / Bulk / Lead Spacing 5.0mm / Lead Style Figure F / Lead Length = 42 mm

**NOTE: Non-Standard Lead Length Required**

CODES	(1)	(2)	(3)	(4)	(5)	(6)	(7)	(8)
PART #	<b>CCD</b>	<b>E</b>	<b>N</b>	<b>680</b>	<b>J</b>	<b>5</b>	<b>F</b>	<b>42</b>

**Ceramic Disc Capacitor** 0.01µF / 500 Volts / 20% / Z5U / Bulk / Lead Spacing 6.0mm / Lead Style Figure A

CODES	(1)	(2)	(3)	(4)	(5)	(6)	(7)
PART #	<b>CCD</b>	<b>F</b>	<b>E</b>	<b>103</b>	<b>M</b>	<b>6</b>	<b>A</b>

**Ceramic Disc Capacitor** 3300pF / 100 Volts / 10% / YPF / Lead Spacing 5.0 mm / Tape & Ammo Kinked Style

CODES	(1)	(2)	(3)	(4)	(5)	(6)	(7)
PART #	<b>CCD</b>	<b>E</b>	<b>L</b>	<b>332</b>	<b>K</b>	<b>5</b>	<b>KA</b>

"TYPE" ON THE NEXT PAGES INCLUDE THE FOLLOWING INFORMATION TO HELP YOU BUILD A PART NUMBER

\* EXAMPLE: TYPE DN-120J (from Page 43)

CODE	(1)	(2)	(3)	(4)	(5)	(6)	(7)	(8)
PART #	<b>CCD</b>	<b>D</b>	<b>N</b>	<b>120</b>	<b>J</b>	<input type="text"/>	<input type="text"/>	<input type="text"/>

AS PER CUSTOMER'S REQUIREMENT



# Class I

## TEMPERATURE STABLE AND COMPENSATING DISC CERAMIC CAPACITORS

**PRO-CAP ELECTRONICS** temperature compensating disc ceramic capacitors provide an accurate, predictable capacitance change as temperature varies. This change is expressed in parts per million per degree C (ppm / °C), and is defined precisely in EIA specifications RS198.

NPO capacitors are typically used in RC networks, tuned circuits and other critical applications where drift free performance is required; N750 and N1500 capacitors are used to compensate for positive changes due to circuit components.

In addition to NPO, N750 and N1500 capacitors, other capacitors with different temperature coefficients can be supplied to meet your specific requirements. The capacitance values listed below are generally considered standard values. Other capacitance values can be supplied as required.

NPO							
50 VDCW				1000 VDCW			
Capac. (pF)	Tol. %	Type	Max. Dia. (in.)	Capac. (pF)	Tol. * %	Type	Max. Dia. (in.)
1.0	± .5 pF	DN-1R0D	.276	1.0	± .5 pF	GN-1R0D	.276
1.5	± .5 pF	DN-1R5D	.276	1.5	± .5 pF	GN-1R5D	.276
1.8	± .5 pF	DN-1R8D	.276	1.8	± .5 pF	GN-1R8D	.276
2.2	± .5 pF	DN-2R2D	.276	2.2	± .5 pF	GN-2R2D	.276
3.3	± .5 pF	DN-3R3D	.276	3.3	± .5 pF	GN-3R3D	.276
4.7	± .5 pF	DN-4R7D	.276	4.7	± .5 pF	GN-4R7D	.276
5.0	± .5 pF	DN-5R0D	.276	5.0	± .5 pF	GN-5R0D	.276
6.0	± .5 pF	DN-6R0D	.276	6.0	± .5 pF	GN-6R0D	.276
6.2	± .5 pF	DN-6R2D	.276	6.2	± .5 pF	GN-6R2D	.276
6.8	± .5 pF	DN-6R8D	.276	6.8	± .5 pF	GN-6R8D	.276
7.5	± .5 pF	DN-7R5D	.276	7.5	± .5 pF	GN-7R5D	.276
8.0	± .5 pF	DN-8R0D	.276	8.0	± .5 pF	GN-8R0D	.276
8.2	± .5 pF	DN-8R2D	.276	8.2	± .5 pF	GN-8R2D	.276
8.8	± 5	DN-8R8J	.276	8.8	± 5	GN-8R8J	.276
9.0	± 5	DN-9R0J	.276	9.0	± 5	GN-9R0J	.276
10	± 5	DN-100J	.276	10	± 5	GN-100J	.276
* 12	± 5	DN-120J	.276	12	± 5	GN-120J	.276
15	± 5	DN-150J	.276	15	± 5	GN-150J	.276
18	± 5	DN-180J	.276	18	± 5	GN-180J	.276
20	± 5	DN-200J	.295	20	± 5	GN-200J	.315
22	± 5	DN-220J	.295	22	± 5	GN-220J	.315
24	± 5	DN-240J	.295	24	± 5	GN-240J	.315
27	± 5	DN-270J	.295	27	± 5	GN-270J	.315
30	± 5	DN-300J	.355	30	± 5	GN-300J	.374
33	± 5	DN-330J	.355	33	± 5	GN-330J	.374
36	± 5	DN-360J	.355	36	± 5	GN-360J	.374
39	± 5	DN-390J	.355	39	± 5	GN-390J	.374
43	± 5	DN-430J	.374	43	± 5	GN-430J	.455
47	± 5	DN-470J	.374	47	± 5	GN-470J	.455
51	± 5	DN-510J	.374	51	± 5	GN-510J	.455
56	± 5	DN-560J	.374	56	± 5	GN-560J	.455
62	± 5	DN-620J	.455	62	± 5	GN-620J	.492
68	± 5	DN-680J	.455	68	± 5	GN-680J	.492
82	± 5	DN-820J	.492	82	± 5	GN-820J	.590
100	± 5	DN-101J	.531	100	± 5	GN-101J	.590
120	± 5	DN-121J	.590	120	± 5	GN-121J	.670
150	± 5	DN-151J	.590	150	± 5	GN-151J	.710

\* K Tolerance (± 10%) also available. Please consult factory.

\* Note: Thickness of all disks -- .156" maximum



# Class I

## TEMPERATURE STABLE AND COMPENSATING DISC CERAMIC CAPACITORS

NPO				S2L			
100 VDCW				100 VDCW			
Capac. (pF)	Tol. %	Type	Max. Dia. (in.)	Capac. (pF)	Tol. * %	Type	Max. Dia. (in.)
1.0	± .5 pF	EN-1R0D	.276	1.0	± .5 pF	EG-1R0D	.276
1.5	± .5 pF	EN-1R5D	.276	1.5	± .5 pF	EG-1R5D	.276
1.8	± .5 pF	EN-1R8D	.276	1.8	± .5 pF	EG-1R8D	.276
2.2	± .5 pF	EN-2R2D	.276	2.2	± .5 pF	EG-2R2D	.276
3.3	± .5 pF	EN-3R3D	.276	3.3	± .5 pF	EG-3R3D	.276
4.7	± .5 pF	EN-4R7D	.276	4.7	± .5 pF	EG-4R7D	.276
5.0	± .5 pF	EN-5R0D	.276	5.0	± .5 pF	EG-5R0D	.276
6.0	± .5 pF	EN-6R0D	.276	6.0	± .5 pF	EG-6R0D	.276
6.2	± .5 pF	EN-6R2D	.276	6.2	± .5 pF	EG-6R2D	.276
6.8	± .5 pF	EN-6R8D	.276	6.8	± .5 pF	EG-6R8D	.276
7.5	± .5 pF	EN-7R5D	.276	7.5	± .5 pF	EG-7R5D	.276
8.0	± .5 pF	EN-8R0D	.276	8.0	± .5 pF	EG-8R0D	.276
8.2	± .5 pF	EN-8R2D	.276	8.2	± .5 pF	EG-8R2D	.276
8.8	± 5	EN-8R8J	.276	8.8	± 5	EG-8R8J	.276
9.0	± 5	EN-9R0J	.276	9.0	± 5	EG-9R0J	.276
10	± 5	EN-100J	.276	10	± 5	EG-100J	.276
12	± 5	EN-120J	.276	12	± 5	EG-120J	.276
15	± 5	EN-150J	.276	15	± 5	EG-150J	.276
18	± 5	EN-180J	.276	18	± 5	EG-180J	.276
20	± 5	EN-200J	.295	20	± 5	EG-200J	.295
22	± 5	EN-220J	.295	22	± 5	EG-220J	.295
24	± 5	EN-240J	.295	24	± 5	EG-240J	.295
27	± 5	EN-270J	.295	27	± 5	EG-270J	.295
30	± 5	EN-300J	.355	30	± 5	EG-300J	.355
33	± 5	EN-330J	.355	33	± 5	EG-330J	.355
36	± 5	EN-360J	.355	36	± 5	EG-360J	.355
39	± 5	EN-390J	.355	39	± 5	EG-390J	.355
43	± 5	EN-430J	.374	43	± 5	EG-430J	.374
47	± 5	EN-470J	.374	47	± 5	EG-470J	.374
51	± 5	EN-510J	.374	51	± 5	EG-510J	.374
56	± 5	EN-560J	.374	56	± 5	EG-560J	.374
62	± 5	EN-620J	.455	62	± 5	EG-620J	.455
68	± 5	EN-680J	.455	68	± 5	EG-680J	.455
82	± 5	EN-820J	.492	82	± 5	EG-820J	.492
100	± 5	EN-101J	.531	100	± 5	EG-101J	.531
120	± 5	EN-121J	.590	120	± 5	EG-121J	.590
150	± 5	EN-151J	.590	150	± 5	EG-151J	.590

N750							
50 VDCW				1000 VDCW			
Capac. (pF)	Tol. %	Type	Max. Dia. (in.)	Capac. (pF)	Tol. * %	Type	Max. Dia. (in.)
10	± 10	DT-100K	.276	10	± 10	GT-100K	.276
15	± 10	DT-150K	.276	15	± 10	GT-150K	.276
22	± 10	DT-220K	.276	22	± 10	GT-220K	.276
33	± 10	DT-330K	.276	33	± 10	GT-330K	.276
47	± 10	DT-470K	.295	47	± 10	GT-470K	.315
68	± 10	DT-680K	.295	68	± 10	GT-680K	.356
82	± 10	DT-820K	.315	82	± 10	GT-820K	.374
100	± 10	DT-101K	.354	100	± 10	GT-101K	.394
120	± 10	DT-121K	.394	120	± 10	GT-121K	.452
150	± 10	DT-151K	.415	150	± 10	GT-151K	.570
180	± 10	DT-181K	.455	180	± 10	GT-181K	.570
220	± 10	DT-221K	.473	220	± 10	GT-221K	.710
330	± 10	DT-331K	.590	330	± 10	GT-331K	.590



# Class II

## GENERAL PURPOSE CAPACITORS

The **PRO-CAP ELECTRONICS** comprehensive family of low voltage disc ceramic capacitors were developed for use in solid state low voltage circuits. These circuits require very small size units along with high capacitance values. As a result, we developed a line of tiny capacitors which optimize size, tolerance and temperature coefficients. This offers the user the least expensive capacitor consistent with circuit requirements. Standard tolerances are  $\pm 20\%$  or  $+80\%$ ,  $-20\%$  with characteristics ideally suited for bypass and coupling.

### LOW VOLTAGE CAPACITORS

Capac. (MFD)	Tol. %	Type	Max. Dia. (in.)	Thick. (in.)
<b>TYPE AA - 12V DCW Y5T</b>				
.05	$\pm 20$	AA-503M	.325	.156
.10	$\pm 20$	AA-104M	.375	.156
.20	$\pm 20$	AA-204M	.556	.156
.47	$\pm 20$	AA-474M	.680	.156
<b>TYPE BA - 16V DCW Y5T</b>				
.010	$\pm 20$	BA-103M	.260	.156
.022	$\pm 20$	BA-223M	.265	.156
.033	$\pm 20$	BA-333M	.295	.156
.047	$\pm 20$	BA-473M	.355	.156
.050	$\pm 20$	BA-503M	.355	.156
.068	$\pm 20$	BA-683M	.385	.156
.100	$\pm 20$	BA-104M	.405	.156
.150	$\pm 20$	BA-154M	.555	.156
.200	$\pm 20$	BA-204M	.670	.156
<b>TYPE CA - 25V DCW Y5T</b>				
.010	$\pm 20$	CA-103M	.260	.156
.022	$\pm 20$	CA-223M	.290	.156
.033	$\pm 20$	CA-333M	.355	.156
.050	$\pm 20$	CA-503M	.395	.156
.068	$\pm 20$	CA-683M	.475	.156
.100	$\pm 20$	CA-104M	.495	.156
<b>TYPE CF - 25V DCW Z5V</b>				
.022	$+80 \pm 20$	CF-223Z	.290	.156
.050	$+80 \pm 20$	CF-503Z	.395	.156
.068	$+80 \pm 20$	CF-683Z	.475	.156
.100	$+80 \pm 20$	CF-104Z	.595	.156
<b>TYPE DE - 50V DCW Z5U</b>				
.001	$\pm 20$	DE-102M	.260	.156
.0047	$\pm 20$	DE-472M	.290	.156
.010	$\pm 20$	DE-103M	.360	.156
.022	$\pm 20$	DE-223M	.415	.156
.033	$\pm 20$	DE-333M	.415	.156
.047	$\pm 20$	DE-473M	.415	.156
.050	$\pm 20$	DE-503M	.415	.156
.068	$\pm 20$	DE-683M	.590	.156
.100	$\pm 20$	DE-104M	.590	.156
.220	$\pm 20$	DE-224M	.590	.156



# Class II

## GENERAL PURPOSE CAPACITORS

### LOW VOLTAGE CAPACITORS (Cont)

Capac. (MFD)	Tol. %	Type	Max. Dia. (in.)	Thick. (in.)
<b>TYPE DF - 50V DCW Z5V</b>				
.001	+80 -20	DF-102Z	.260	.156
.0033	+80 -20	DF-332Z	.260	.156
.005	+80 -20	DF-502Z	.260	.156
.010	+80 -20	DF-103Z	.290	.156
.020	+80 -20	DF-203Z	.355	.156
.025	+80 -20	DF-253Z	.415	.156
.030	+80 -20	DF-303Z	.415	.156
.047	+80 -20	DF-473Z	.495	.156
.050	+80 -20	DF-503Z	.495	.156
.068	+80 -20	DF-683Z	.555	.156
.100	+80 -20	DF-104Z	.670	.156
.220	+80 -20	DF-224Z	.670	.156
<b>TYPE DL - 50V DCW Y5P</b>				
* 470 pF	± 10	DL-471K	.260	.156
.0020	± 10	DL-202K	.260	.156
.0022	± 10	DL-222K	.260	.156
.0047	± 10	DL-472K	.260	.156
<b>TYPE EE - 100V DCW Z5U</b>				
.003	± 20	EE-302M	.60	.156
.005	± 20	EE-502M	.260	.156
.0068	± 20	EE-682M	.290	.156
.010	± 20	EE-103M	.355	.156
.015	± 20	EE-153M	.355	.156
.020	± 20	EE-203M	.415	.156
.022	± 20	EE-223M	.475	.156
.025	± 20	EE-253M	.475	.156
.030	± 20	EE-303M	.475	.156
.050	± 20	EE-503M	.590	.156
.100	± 20	EE-104M	.910	.156
.100	+80 -20	EE-104Z	.910	.156
<b>TYPE EF - 100V DCW Z5V</b>				
.005	+80 -20	EF-502Z	.260	.156
.010	+80 -20	EF-103Z	.290	.156
.020	+80 -20	EF-203Z	.355	.156
.025	+80 -20	EF-253Z	.415	.156
.030	+80 -20	EF-303Z	.415	.156
.050	+80 -20	EF-503Z	.485	.156
.100	+80 -20	EF-104Z	.700	.156



# Class II

## 500/600/1000 VOLT GENERAL PURPOSE

The **PRO-CAP ELECTRONICS** family of general purpose 500/600 and 1000 volt DC disc ceramic offer the designer a wide choice of capacitance values and tight tolerances as well as small size. These high dielectric ceramic discs have a rugged durez, wax impregnated coating that offers a high degree of environmental resistance.

Capac. (MFD)	Tol. %	Type	Char.	Max. Dia. (in.)	Thick. (in.)
<b>TYPE F - 500V DCW General Purpose</b>					
3300 pF	± 10	FL-332K	Y5P	.355	.150
.01 µF	+80 -20	FF-103Z	Z5V	.390	.250
.01 µF	± 20	FE-103M	Z5U	.390	.250
.1 µF	± 20	FE-104M	Z5U	.930	.250
.1 µF	+80 -20	FE-104Z	Z5U	.930	.250
.47 µF	+80 -20	FF-474Z	Z5V	.930	.250
<b>TYPE G - 600V DCW General Purpose</b>					
.015 µF	+80 -20	GE-153Z	Z5U	.670	.156
.015 µF	+80 -20	GF-153Z	Z5V	.551	.156
.02 µF	+80 -20	GE-203Z	Z5U	.690	.156
.02 µF	+80 -20	GF-203Z	Z5V	.590	.156
.03 µF	+80 -20	GE-303Z	Z5U	.875	.156
.03 µF	+80 -20	GF-303Z	Z5V	.690	.156
.05 µF	+80 -20	GE-503Z	Z5U	.985	.156
.05 µF	+80 -20	GF-503Z	Z5V	.985	.156
.05 µF	GMV	GE-503G	Z5U	.590	.156
.05 µF	GMV	GF-503G	Z5V	.490	.156
<b>TYPE G - 1000V DCW General Purpose</b>					
3.3 pF	± 5	GG-3R3J	S2L	.290	.156
5.0 pF	± 10	GG-5R0K	S2L	.290	.156
6.0 pF	± 10	GG-6R0K	S2L	.290	.156
6.8 pF	± 10	GG-6R8K	S2L	.290	.156
7.5 pF	± 10	GG-7R5K	S2L	.290	.156
8.0 pF	± 10	GG-8R0K	S2L	.290	.156
10 pF	± 10	GG-100K	S2L	.290	.156
12 pF	± 10	GG-120K	S2L	.290	.156
15 pF	± 10	GG-150K	S2L	.290	.156
18 pF	± 10	GG-180K	S2L	.290	.156
20 pF	± 10	GG-200K	S2L	.290	.156
22 pF	± 10	GG220K	S2L	.290	.156
24 pF	± 10	GG-240K	S2L	.290	.156
25 pF	± 10	GG-250K	S2L	.290	.156
27 pF	± 10	GG-270K	S2L	.290	.156
30 pF	± 10	GH-300K	S3N	.290	.156
33 pF	± 10	GH-330K	S3N	.290	.156
39 pF	± 10	GH-390K	S3N	.290	.156
47 pF	± 10	GH-470K	S3N	.290	.156
50 pF	± 10	GH-500K	S3N	.290	.156
51 pF	± 10	GH-510K	S3N	.290	.156
56 pF	± 10	GH-560K	S3N	.290	.156
68 pF	± 10	GH-680K	S3N	.290	.156
75 pF	± 10	GH-750K	S3N	.290	.156
82 pF	± 10	GH-820K	S3N	.290	.156



# Class II

## 500/600/1000 VOLT GENERAL PURPOSE

TYPE G - 1000V DCW General Purpose					
Capac. (pF)	Tol. %	Type	Char.	Max. Dia. (in.)	Thick. (in.)
91	± 10	GH-910K	S3N	.290	.156
100	± 10	GH-101K	S3N	.290	.156
120	± 10	GH-121K	S3N	.290	.156
130	± 10	GH-131K	S3N	.290	.156
150	± 10	GH-151K	S3N	.290	.156
180	± 10	GH-181K	S3N	.290	.156
200	± 10	GH-201K	S3N	.290	.156
200	± 10	GB-201K	Z5F	.290	.156
220	± 10	GB-221K	Z5F	.290	.156
240	± 10	GB-241K	Z5F	.290	.156
250	± 10	GB-251K	Z5F	.290	.156
270	± 10	GB-271K	Z5F	.290	.156
300	± 10	GB-301K	Z5F	.290	.156
330	± 10	GB-331K	Z5F	.290	.156
360	± 10	GB-361K	Z5F	.290	.156
390	± 10	GB-391K	Z5F	.290	.156
470	± 10	GB-471K	Z5F	.290	.156
500	± 10	GB-501K	Z5F	.290	.156
510	± 10	GB-511K	Z5F	.290	.156
560	± 10	GB-561K	Z5F	.290	.156
680	± 10	GC-681K	Z5R	.290	.156
750	± 20	GC-751M	Z5R	.290	.156
800	GMV	GE-801G	Z5U	.290	.156
800	± 10	GE-801K	Z5U	.290	.156
820	± 20	GB-821M	Z5F	.290	.156
820	± 20	GE-821M	Z5U	.290	.156
910	± 20	GB-911M	Z5F	.290	.156
910	± 10	GE-911K	Z5U	.290	.156
1000	± 10	GL-102K	Y5P	.355	.156
1000	± 20	GB-102M	Z5F	.355	.156
1000	± 10	GE-102K	Z5U	.290	.156
1200	± 10	GC-122K	Z5R	.355	.156
1300	± 10	GC-132K	Z5R	.355	.156
1500	± 10	GC-152K	Z5R	.355	.156
1500	GMV	GB-152G	Z5F	.290	.156
1600	± 20	GE-162M	Z5U	.355	.156
1800	± 20	GE-182M	Z5U	.355	.156
2000	± 20	GE-202M	Z5U	.355	.156
2000	GMV	GE-202G	Z5U	.355	.156
2200	± 10	GB-222K	Z5F	.315	.156
2200	± 10	GE-222K	Z5U	.415	.156
2200	± 20	GE-222M	Z5U	.355	.156
2200	GMV	GE-222G	Z5U	.355	.156
2500	± 20	GE-252M	Z5U	.355	.156
2500	GMV	GE-252G	Z5U	.355	.156
2700	± 20	GE-272M	Z5U	.355	.156
2700	GMV	GE-272G	Z5U	.355	.156
3000	± 10	GB-302K	Z5F	.495	.156
3000	± 20	GE-302M	Z5U	.355	.156

\* Example:  
Page 39



# Class II

## 500/600/1000 VOLT GENERAL PURPOSE

1000V DCW General Purpose continued					
Capac. (pF)	Tol. %	Type	Char.	Max. Dia. (in.)	Thick. (in.)
3000	GMV	GE-302G	Z5U	.355	.156
3300	± 20	GE-332M	Z5U	.415	.156
3300	GMV	GE-332G	Z5U	.415	.156
3900	± 20	GE-392M	Z5U	.415	.156
3900	GMV	GE-392G	Z5U	.415	.156
4000	± 20	GE-402M	Z5U	.415	.156
4000	GMV	GE-402G	Z5U	.415	.156
4300	± 20	GE-432M	Z5U	.415	.156
4300	GMV	GE-432G	Z5U	.415	.156
4700	± 20	GE-472M	Z5U	.415	.156
5000	± 10	GB-502K	Z5F	.590	.156
5000	± 20	GE-502M	Z5U	.415	.156
5600	± 20	GE-562M	Z5U	.590	.156
5600	GMV	GE-562G	Z5U	.590	.156
6800	± 10	GE-682K	Z5U	.638	.156
6800	± 10	GB-682K	Z5F	.590	.156
6800	GMV	GE-682G	Z5U	.590	.156
7500	± 20	GE-752M	Z5U	.590	.156
7500	GMV	GE-752G	Z5U	.590	.156
8200	± 20	GE-822M	Z5U	.590	.156
8200	GMV	GE-822G	Z5U	.590	.156
10000	± 20	GE-103M	Z5U	.590	.156



**HIGH VOLTAGE CAPACITORS**

	2000 VDCW		3000 VDCW		5000 VDCW	
	Tol. ±20% Temp. Char. Z5U		Tol. ±20% Temp. Char. Z5U		Tol. ±20% Temp. Char. Z5U	
Capac. (pF)	Type	Maximum Diameter (inches)	Type	Maximum Diameter (inches)	Type	Maximum Diameter (inches)
82	H2E-820M	.315	H3E-820M	.355	H5E-820M	.415
91	H2E-910M	.315	H3E-910M	.355	H5E-910M	.415
100	H2E-101M	.315	H3E-101M	.355	H5E-101M	.415
120	H2E-121M	.315	H3E-121M	.355	H5E-121M	.415
150	H2E-151M	.315	H3E-151M	.355	H5E-151M	.415
180	H2E-181M	.315	H3E-181M	.355	H5E-181M	.435
200	H2E-201M	.315	H3E-201M	.355	H5E-201M	.435
220	H2E-221M	.315	H3E-221M	.355	H5E-221M	.435
240	H2E-241M	.315	H3E-241M	.355	H5E-241M	.435
270	H2E-271M	.315	H3E-271M	.355	H5E-271M	.435
300	H2E-301M	.315	H3E-301M	.355	H5E-301M	.435
330	H2E-331M	.315	H3E-331M	.355	H5E-331M	.512
390	H2E-391M	.315	H3E-391M	.355	H5E-391M	.512
470	H2E-471M	.315	H3E-471M	.375	H5E-471M	.512
560	H2E-561M	.355	H3E-561M	.375	H5E-561M	.555
680	H2E-681M	.355	H3E-681M	.375	H5E-681M	.555
750	H2E-751M	.355	H3E-751M	.375	H5E-751M	.630
820	H2E-821M	.355	H3E-821M	.375	H5E-821M	.630
910	H2E-911M	.355	H3E-911M	.375	H5E-911M	.630
1000	H2E-102M	.355	H3E-102M	.375	H5E-102M	.710
1200	H2E-122M	.355	H3E-122M	.375	H5E-122M	.710
1500	H2E-152M	.415	H3E-152M	.415	H5E-152M	.867
1800	H2E-182M	.415	H3E-182M	.415	H5E-182M	.945
2000	H2E-202M	.415	H3E-202M	.415	H5E-202M	.950
2200	H2E-222M	.415	H3E-222M	.475	H5E-222M	.950
2700	H2E-272M	.415	H3E-272M	.475		
3000	H2E-302M	.475	H3E-302M	.590		
3300	H2E-332M	.475	H3E-332M	.590		
3900	H2E-392M	.475	H3E-392M	.590		
4700	H2E-472M	.532	H3E-472M	.670		
5600	H2E-562M	.532	H3E-562M	.670		
6800	H2E-682M	.630	H3E-682M	.730		
7500	H2E-752M	.630	H3E-752M	.790		
8200	H2E-822M	.710	H3E-822M	.910		
9100	H2E-912M	.710	H3E-912M	.910		
10000	H2E-103M	.710	H3E-103M	.910		
12000	H2E-123M	.710				
15000	H2E-153M	.790				
18000	H2E-183M	.910				
20000	H2E-203M	.910				

Max. Thickness: .250 inches