

THIS DOCUMENT IS THE PROPERTY OF KEYSTONE ELECTRONICS CORP. AND SHALL NOT BE REPRODUCED, DISTRIBUTED OR USED AS A BASIS FOR MANUFACTURE WITHOUT PRIOR WRITTEN PERMISSION FROM KEYSTONE ELECTRONICS CORP.

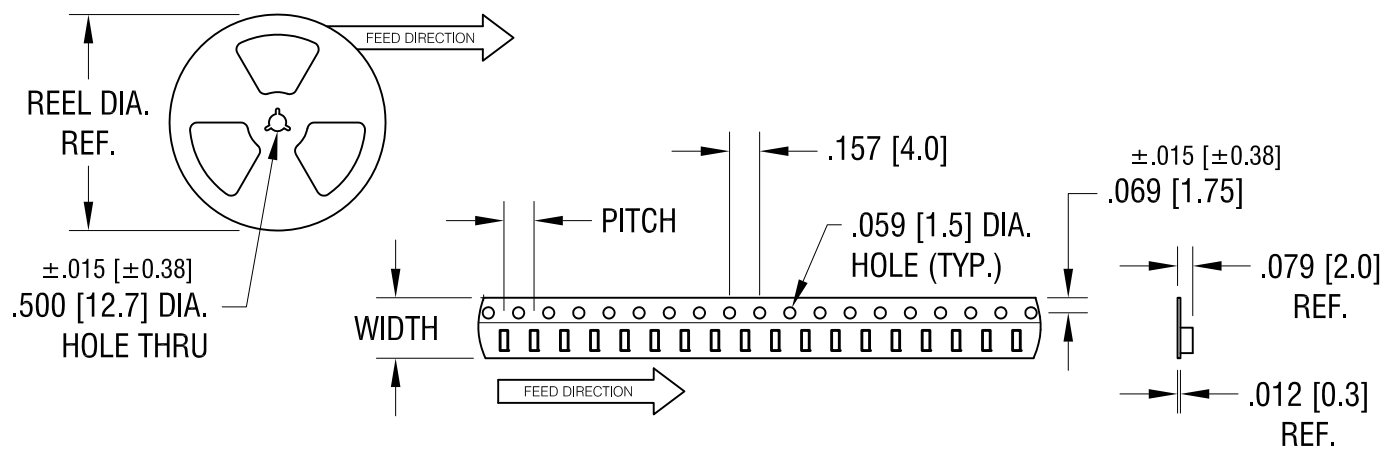
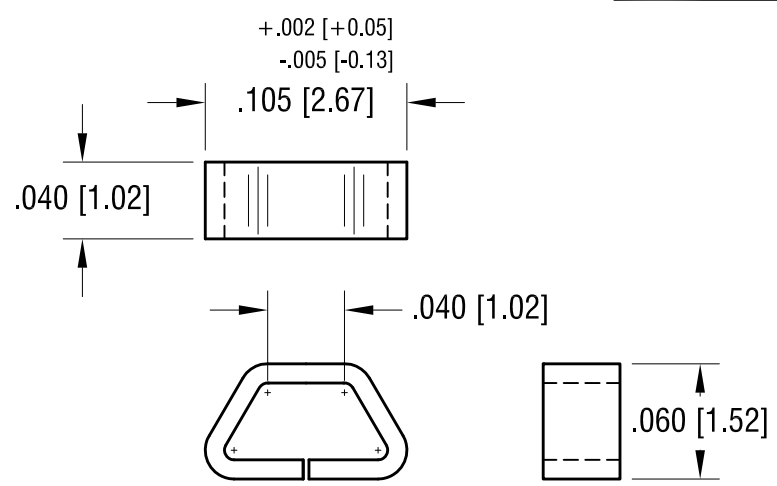
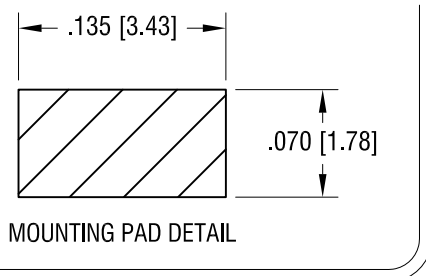

NOTES:

- SUPPLIED ON TAPE AND REEL ONLY.
TAPE AND REEL SPECIFICATIONS:
- TAPE:
MAT'L - ALL CONDUCTIVE POLYSTYRENE CARRIER
ANSI/EIA-481 STANDARD
.315 [8.0] WIDE; .157 [4.0] PITCH

- REEL:
7.0 [177.8] DIA. 1000 PIECES OF
PART NO. 5015 PER REEL.

KEYSTONE ELECTRONICS CORP.			
www.keyelco.com • ASTORIA, N.Y. 11105-2017 • Tel (718) 956-8900			
PART NAME		TEST POINT, MINIATURE, SURFACE MOUNT	
MATERIAL		.010 [0.25] TH'K PHOSPHOR BRONZE	
FINISH		DRN BY	DATE
SILVER PLATE		BOONE	5.1.01
		APP'D	SCALE
			10X, 1X
TOLERANCES	INCH [MM]	CODE	DWG NO.
DECIMAL	± .005 [± 0.13]	C	5015
ANGULAR	± 1°		
UNLESS OTHERWISE SPECIFIED			

6.18.15	PER ECN 15-063 F1 WAS [±0.15]	F
3.18.14	CHANGE AS PER ECN 14-030	E
6.21.12	CHANGE AS PER ECN 12-079	D
3.11.10	CHANGE AS PER ECN 10-022	C
DATE	DESCRIPTION	REV.